

“Blue Hot Mamas”

Teacher Guide

Karen Daniels and Erika Merschrod
Cornell Center for Materials Research, Research Experience for Teachers
19 July 2000

INTRODUCTION

We will investigate the relationship between color, wavelength and energy for the visible spectrum of light using light emitting diodes (LEDs). These are electronic components which pass current in only one direction. When current flows through an LED, the energy from that current is converted into light of a particular wavelength associated with the material inside the LED. These wavelengths are usually printed on the packaging of the LED, and many different colors are available. For a particular material, only certain wavelengths are possible.

Visible light is just one part of the electromagnetic spectrum, and different colors are distinguished by their different wavelengths (or, equivalently, frequencies). When all wavelengths of visible light are shone together, the result is “white light.” The spectrum nature of this white light can be revealed using a diffraction grating or prism, which bends different wavelengths of light by different amounts.

DEMO: Shine an overhead projector or slide projector through a diffraction grating or prism. Have students note that the colors are spread out in a particular order, which they will recognize from rainbows. Beyond the red is infrared radiation, and beyond the blue is ultraviolet, neither of which are visible to the naked eye.

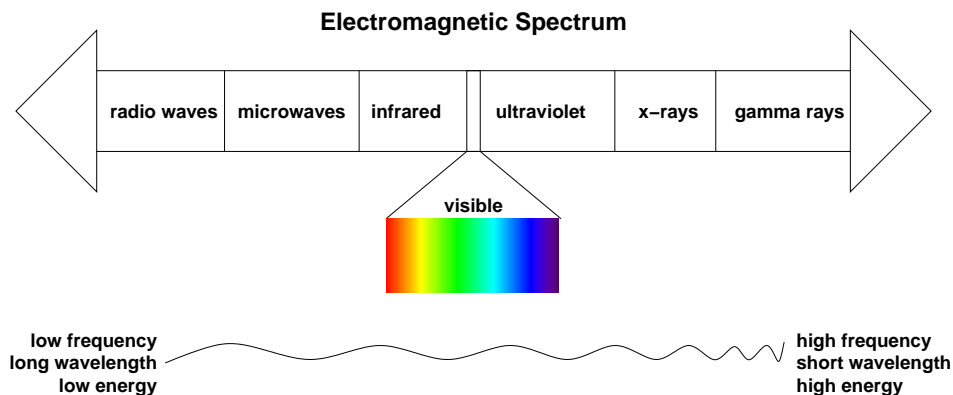

Figure 1: The electromagnetic spectrum.

All waves, whether light, sound, water or stadium, travel at a specific velocity. If you make one of these types of waves with a particular frequency, they will always have the same wavelength.

DEMO: Have a pair of students hold opposite ends of the rope on the surface of a slippery floor while the others gather around. One student should hold their end steady with the other waves their end back and forth at first slowly (low frequency), then more quickly (high frequency). Have students observe that a high-frequency wave is shorter in wavelength. It also takes more energy to make a high-frequency wave, for a constant amplitude.

We can think about a similar situation for a train, for example. If we were standing beside the track trying to figure out how fast it was going, we might count 15 train cars going by each minute (60 seconds) – this is a frequency, f

$$f = \frac{15 \text{ cars}}{60 \text{ sec}} = 0.25 \text{ Hz}$$

Later, when the train stops, we could measure the length of the cars and find that they are 8 meters long (analogous to a wavelength). From this, we can determine the speed that the train had been traveling.

$$\text{speed} = 8 \text{ meters} \times 0.25 \text{ Hz} = 2 \text{ meters/sec}$$

We can also picture a train traveling along at a constant speed, but with a second type of car at the back end of the train: these are only 6 meters long. Since the train speed is still constant, the frequency with which we observe passing cars must increase when we get to the section with the shorter cars, as it did with the rope waves.

$$f = \frac{2 \text{ meters/sec}}{6 \text{ meters}} = 0.33 \text{ Hz} = \frac{20 \text{ cars}}{60 \text{ sec}}$$

It is convenient to describe light in terms of its frequency, wavelength or energy. As with the train example, the unit for frequency is Hertz, abbreviated Hz. One Hertz is one cycle per second, 1/sec. Wavelengths are often measured in meters or fractions of meters: micrometers (10^{-6} m, also called microns), nanometers (10^{-9} m), Ångstroms (10^{-10} m), *etc.*

All types of light are composed of the same oscillations of electric and magnetic fields, but at longer or shorter wavelengths. Regardless of wavelength, all light travels at a constant speed, $c = 3 \times 10^8 \text{ m/s}$, and the product of the wavelength and the frequency (in appropriate units) will always give this value. Thus, the higher the frequency, the shorter the wavelength, as with the rope waves in the demo and the train-car examples.

$$c = \lambda f \tag{1}$$

$$\begin{aligned} \text{wave speed} &= \text{wavelength} \times \text{frequency} \\ [\text{meters/sec}] &= [\text{meters}] \times [\text{Hertz}] \end{aligned}$$

It is useful to remember that light is just another form of energy: chemical energy and electrical energy are some other common types. There are many units for energy in use today: Joules ($1 \text{ J} = 1 \text{ kg m}^2/\text{s}^2$), calories ($1 \text{ cal} = 4.186 \text{ J}$), and electron volts ($1 \text{ eV} = 1.6 \times 10^{-19} \text{ J}$) are a few examples. If we recall that electron volts are a measure of the energy of an electron (of charge q) in a electric potential (of voltage V); we see therefore that energy can be defined as charge \times voltage. Since the units of charge are Coulombs (C), $1 \text{ Volt} = 1 \text{ Joule/Coulomb}$.

We already discovered how to relate the wavelength and frequency of light, and one of the earliest advances in quantum mechanics was the relation Max Planck found between the energy of light and its frequency.

$$E = hf \tag{2}$$

$$\begin{aligned} \text{energy} &= \text{Planck's constant} \times \text{frequency} \\ [\text{Joules}] &= [\text{Joules} \cdot \text{sec}] \times [\text{Hertz}] \end{aligned}$$

As the twentieth century has progressed, Planck's constant has found its way to the heart of our quantum mechanical description of the universe: it signifies the finest scale to which we can probe.

LIGHT EMITTING DIODES

Light emitting diodes are common in many electronic devices because they consume very little electricity. The reason for this is that the process which allows them to release photons is a fundamental one, and there are very few "losses," as with the heat produced by standard incandescent lightbulbs.

A lightbulb is basically a thin piece of (tungsten) wire. When the current passes through the wire it encounters some resistance (from the atomic structure of the wire, the polycrystalline nature of the wire, other defects in the wire, *etc.*). This resistance leads to heating, and the heated wire gives off radiation of a wide range of wavelengths known as "blackbody radiation." Most of the energy consumed by the wire is given off in heat, so lightbulbs are very inefficient light sources. In contrast, all of the energy consumed by the LED goes into electron excitation, which leads to emission of a particular wavelength.

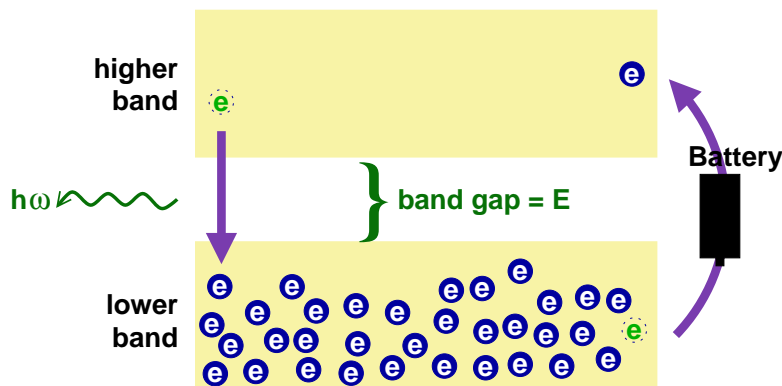

Figure 2: Schematic of energy bands. Battery pumps electrons up to higher-energy band, and they fall back down to the lower-energy band, emitting light.

The crucial material inside an LED is a semiconductor, which has certain electronic properties. All electrons (on any atom) have a particular energy, so we say that they “reside” in a particular energy level. In a solid system (a semiconductor, a metal) there are many levels with the same energy, and many more with similar energies, so the levels are grouped in “bands.” In a semiconductor, there is an energy gap E (where there are no levels) between the band with the highest-energy electrons and the lowest-energy empty band; this is the energy gap which is crossed by excited electrons when a current is passed through the LED. (See Figure 2.)

The battery provides energy to lift electrons to the highest-energy level from the lowest-energy level. When the electrons relax back to their initial energy, they emit light of energy E , the same energy it took to lift them. For each electron which falls across the band gap, a photon with this energy is released. To make LEDs of different colors, different semiconductors are used so that the gap between the levels has a different energy.

A more detailed explanation can be found at Washington University:

<http://wunmr.wustl.edu/EduDev/LabTutorials/PeriodicProperties/MetalBonding/MetalBonding.html>

LED LABORATORY EXERCISE

SETUP

Students will construct a simple electric circuit composed of a battery (energy source), an LED (source of single-wavelength light), and a resistor (dissipates excess power). Figure 3 shows how this is to be done, using standard electrical symbols. Note that the resistor and the battery both have “direction” to them: if one is reversed with respect to the other, the LED will not light up. The battery will be labelled \oplus and \ominus , and the flat edge of the LED corresponds to the flat line shown in the circuit diagram. The resistor can face either direction within the circuit, and lie on either side of the LED.

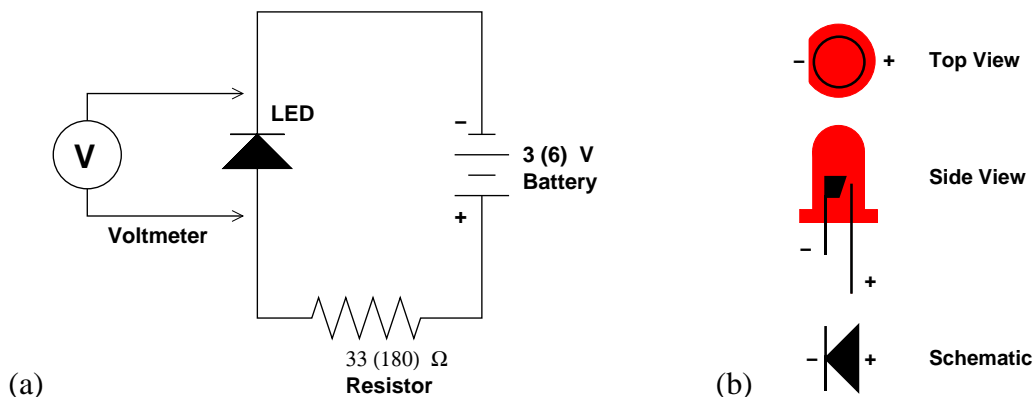

Figure 3: (a) Circuit diagram for LEDs. The resistor can go on either side of the LED. (b) Locating the cathode (–) and anode (+) on a LED, so that it can be properly oriented within the circuit.

Color	Wavelength λ (nm)	Voltage V (volts)	Frequency (Hz) $f = c/\lambda$	Energy (J) $E = qV$	Planck constant $h = E/f$ ($J \cdot s$)
infrared	940	1.35	3.3×10^{14}	2.16×10^{-19}	6.55×10^{-34}
red	700	1.70			
orange	620	2.09			
yellow	585	2.14			
green	565	2.26			
blue	466	3.20			

Figure 4: Sample data for a set of six LEDs. Wavelength values taken from manufacturer’s information, voltages measured, and remaining columns calculated.

When the circuit is constructed correctly, the LED will light up. If it does not, try reversing the direction of the LED with respect to the battery, consulting Figure 3b for correct orientation.

Each group will need a collection of 4 to 6 different colored LEDs, each soldered to a resistor appropriate for the battery voltage, and a battery setup to provide power. The soldering can be done beforehand, or included as part of the lab activities. The battery should be either 3 or 6 V, most easily provided by a pair of AA batteries in a battery holder or a 6V lantern battery. For the 3V battery, a 33Ω resistor should be used, while a 180Ω resistor is appropriate for use in a 6V. It is possible for each group to get only a few LEDs at a time, and swap with another group when they are done, so that the total number of LED setups is reduced. Because blue LEDs will need to use approximately 3 V in order to light up, they will work best with 6 V setups.

TAKING MEASUREMENTS

For each color LED, attach the leads to the battery so that the light turns on. Measure the voltage drop (energy used) across the LED using the multimeter, as shown in Figure 3. Record the voltage and the wavelength (from tag, packaging, or catalog) for each LED in the collection.

If you and/or the students are unfamiliar with the use of multimeters, the following tips will help. Since we are measuring *voltage* and not current, care must be taken that the leads of the multimeter are attached to the appropriate terminals on the multimeter (generally marked – and + or COM and $V\Omega$). There may also be a dial which must be set to “V” to measure voltage, and sometimes a correct range must be chosen as well.

ANALYSIS

Students should graph wavelength (or frequency) vs. voltage (or energy) to see the relationship. From this point, several levels of sophistication are possible. While wavelength is the value given on the package of the LED, the frequency (f) is the more physically interesting quantity, since it is related to the energy (E) of the light by Planck’s constant (h).

Therefore, students can determine a value for Planck’s constant by converting voltage to energy ($E = qV$, where q is the charge on an electron) and wavelength to frequency ($c = \lambda f$) in whatever units they are comfortable with. The slope of an energy vs. frequency graph will give a value for Planck’s constant for a line which goes through the origin.

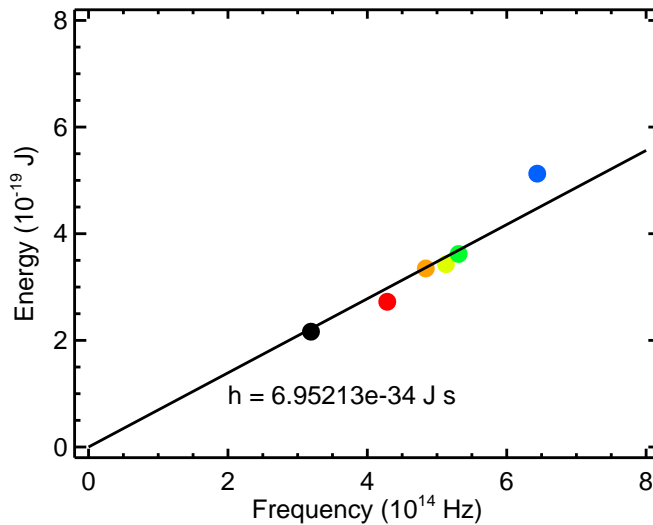

Figure 5: Sample graph for a set of LEDs: frequency vs. energy, with best fit line through origin plotted and experimental value for h (slope) shown.

If doing the conversions and fitting is not desirable, a simple graph of voltage vs. wavelength will still show a trend which can be discussed qualitatively, and even used for extrapolation and interpolation. A sample student handout suitable for use in grades 6 – 8 is available which uses mostly qualitative reasoning.

$c = 3 \times 10^8 \text{ m/s}^2$	speed of light
$q = 1.602 \times 10^{-19} \text{ Coulomb}$	electronic charge
$h = 6.626 \times 10^{-34} \text{ Joule} \cdot \text{s}$	Planck's constant

To determine Planck's constant h in the most common units of $J \cdot s$, unit conversion will be a necessary part of the lab. Wavelength will be given in \AA (Ångstroms, 10^{-10} meters) or nm (nanometers, 10^{-9} meters), so this conversion is fairly simple. Frequency is determined from Equation 1, with the resulting units in Hz (sec^{-1}). Remember, this is motivated by the rope demonstration.

For the energy part of the calculation, it is useful to consider what happens within the circuit. Conceptually, electrons leave the battery with some voltage (3V or 6V, depending on the setup). This voltage is the energy per unit charge on the electron, and the electrons will have lost it all by the time they get around to the other end of the battery. The LED will take whatever energy it needs (to produce light, another form of energy) and the rest will be used up in the resistor (which heats up over time as a result). So, to determine the energy of the light, we just need to multiply the voltage (1 volt = 1 Joule/Coulomb) by the charge on the electron (1.602×10^{-19} Coulomb) to get the energy of the light produced by each electron, in Joules.

What is a Joule? It would take 1 Joule of energy to lift a 1 kg weight by 10 cm. If we want to work outside the metric system, another example would be to lift a 5 lb bag of flour by 1.7

inches. You could also calculate the total number of Joules being released per second by the LEDs by measuring the current with the multimeter, the value for which will be given in Coulombs/sec (Amperes).

MYSTERY LED

The teacher should prepare an LED (or enough for each group to have their own) wrapped in black electrical tape or enclosed in a film canister, but with the leads exposed for testing. Students can use their multimeters to determine the voltage drop across the resistor, and interpolate/extrapolate from their graph to determine a wavelength and predict a color. When all predictions are in, the color can be revealed.

If an infrared LED is used for this section, it can lead to a discussion about other parts of the electromagnetic spectrum. While the light is not visible to the naked eye, it still behaves in the same way as with the other LEDs. One nice feature of digital cameras is that they are sensitive to “near” infrared light, allowing students to indirectly see the light emitted from the LEDs if you have one available.

REFERENCES

Patrick J. O’Connor and Leah R. O’Connor. “Measuring Planck’s constant using a light emitting diode.” *The Physics Teacher*. **12**: 423 (1974).

F. Herrmann and D. Schätzle. “Question #53. Measuring Planck’s constant by means of and LED.” *American Journal of Physics*. **64**: 1448 (1996).

L. Nieves, G. Spavieri, B. Fernandez, and R. A. Guevara. “Measuring the Planck Constant with LEDs.” *The Physics Teacher*. **35**: 108 (1997).

Roger Morehouse. “Answer to Question #53. Measuring Planck’s constant by means of and LED.” *American Journal of Physics*. **66**: 12 (1998).

MATERIALS

FOR EACH LAB GROUP

- a selection of different colored LEDs tagged with their wavelength and with a $33\ \Omega$ resistor soldered to each.
- pair of AA batteries (1.5V each) in a battery pack (it is possible to substitute a 6V lantern battery with screw-on terminals if the $33\ \Omega$ resistor is replaced with one of $180\ \Omega$)
- “mystery” LED (infrared for extrapolation or orange for interpolation), taped over or hidden in film canister with leads poking out
- multimeter
- graph paper, ruler, calculator
- lab instruction sheet

FOR CLASS DEMOS

- 6 to 10 ft. flexible rope with center marked with pen
- colimated white light source (overhead or slide projector)
- diffraction grating or prism
- electromagnetic spectrum chart

PREPARING THE ELECTRONICS

When soldering the LEDs to the resistors, take care not to allow the LED to become too hot. This can be avoided by holding the leg being soldered with a pair of metal pliers or an alligator clip to act as a heat sink. The resistors can be soldered on either side, but being consistent with the circuit diagram helps insure that the LEDs are placed into the circuit facing the correct direction.

If battery holders are being used, it helps to solder alligator clips to the terminals on the holders. This means that students can quickly and securely clip the LED setups into the circuit. If 6V lantern batteries are being used, they have screw-down terminals which are most easily used if flexible wire leads are soldered to the ends of the LED setups.

SOURCES FOR MATERIALS

Radio Shack generally carries red, yellow, and green LEDs, and other colors may be specially ordered. Hosfelt Electronics (<http://www.hosfelt.com>) carries more exotic LEDs for reasonable prices.

Wherever the LEDs are purchased, be sure that the wavelength (in nm or Å) is printed in the catalog or on the packaging, since this information is needed for the quantitative parts of the laboratory exercise.

EXTENSIONS

Connections to many branches of science and math are possible. Below are general discussion questions, as well as suggested activities pertaining to various subjects. References are provided for obtaining more information.

ASTRONOMY

TAKING THE TEMPERATURE OF A STAR

While stars generally look whitish, a more careful examination reveals that some of them are reddish while others are bluish. This is due to their differing surface temperatures. Stars on the “main sequence” range from hot, blue stars (high mass) to cooler, red stars (lower mass). Astronomers plot these values on a Hertzsprung-Russell (HR) diagram. One easy-to-spot example of a red star

is Betelgeuse in the constellation Orion. These concepts are related to those of blackbody radiation, listed under “Physics” below.

Science Museum of Virginia: “How Hot is that Star?”

<http://www.smv.org/jims/unit.htm>

University of Colorado, Boulder: “Physics 2000”

<http://www.colorado.edu/physics/2000/index.pl>

EXPLORING THE UNIVERSE IN DIFFERENT WAVELENGTHS

Until recently, astronomers could only explore the night sky using their eyes and telescopes, limiting their vision to the “visible spectrum.” New technologies allow them to explore using all parts of the electromagnetic spectrum, frequently by placing telescopes above the earth’s atmosphere, in orbit.

Hubble Space Telescope

<http://www.stsci.edu/>

Space Infrared Telescope Facility

<http://sirtf.jpl.nasa.gov/>

Chandra X-ray Observatory

<http://xanth.msfc.nasa.gov/xray/axafps.html>

Compton Gamma Ray Observatory

<http://coss.cgsfc.nasa.gov/>

Exploratorium: “Spectra from Space”

http://www.exploratorium.edu/spectra_from_space/

Center for Science Education: “Light Tour” of different wavelengths of light

<http://cse.ssl.berkeley.edu/light/light.tour.html>

BIOLOGY

CHLOROPHYLL, PHOTOSYNTHESIS, AND THE SUN

Photosynthesis, the conversion of radiant energy from sunlight to chemical energy in plants, works on the same principle as the LEDs: a particular material (the chlorophyll molecule in this case) can absorb a certain amount of energy of one kind and emit that energy in another form. The LED takes in a particular amount of energy from an electric current and emits light of a particular energy (wavelength). The chlorophyll takes in a particular wavelength from sunlight and converts that to

chemical energy. The sunlight excites an electron in the chlorophyll, and then the excited electron can be transferred to other molecules to stimulate particular reactions. Eventually, the plant can use this energy to convert CO_2 and H_2O to the sugar for food.

Students can observe the electron transfer process (oxidation/reduction) indirectly by adding a suitable dye to chloroplasts from plants. As the chlorophyll absorbs light, electrons are excited. The dye acts as an acceptor for the electron from the chlorophyll; the dye is reduced and the chlorophyll is oxidized. DCPIP is a good dye for this, because it is blue in its oxidized state and colorless when it is reduced. Thus, students can observe the color change in the dye, which indicates that the first step in photosynthesis is occurring. This experiment takes a fair bit of preparation, as it involves harvesting the chloroplasts – often from spinach (using a blender and some chemicals for extraction).

A description of this lab is given in: Dean, R. L. *The American Biology Teacher*, **58**, 303–6 (1996)

RODS AND CONES IN THE EYE

We can see because of cells called *rods* and *cones*. When light hits the eye, it travels through the pupil to the retina, where the cones and rods are located. In these cells, the light causes a chemical reaction which translates the light into a message for your brain. The rod cells contain *rhodopsin* and the cone cells contain *retinal*. The retinal molecules absorb light of particular frequencies (red, green, or blue) and then release corresponding amounts of energy which is converted to an electrical signal in the brain. So in a sense, they work in the opposite direction from the LEDs. Because cone cells are sensitive to only three colors, these are the primary colors of light, which are not the same as the primary colors of pigments.

The Tech Museum of Innovation in San Jose

http://www.thetech.org/exhibits_events/online/color/vision/

The Howard Hughes Medical Institute

<http://www.hhmi.org/senses/b/b110.htm>

Red, green, and blue color-mixing applet

<http://www.phy.ntnu.edu.tw/~hwang/image/rgbColor.html>

CHEMISTRY

FIREWORKS! (FLAME TESTS)

Flame tests are used to identify ions in a salt (sodium in table salt, potassium in potassium iodide, etc). The flame color indicates the energy given off by an excited electron as it returns to its ground state. (The heat from the flame excites the electron initially.) The students can relate the color of the flame to the atomic structure, *i.e.* why would it take more (less) energy to excite an electron in one atom or another?

There are many ways to do a flame test; the easiest is to just put a mound of salt on a dish, add methanol, and light! (Methanol is a poison; do not ingest.) Some salts to try: NaCl (yellow), KCl (violet), BaCl₂ (green-yellow), SrCl₂ (red).

There are many references available in the *Journal of Chemical Education*.

ABSORPTION SPECTRA OF CONJUGATED DYES

A dye can be thought of as a box of a certain size in which an electron can move. The size of the “box” determines the energy of the highest-energy electrons (the ones that are moving): the smaller the box, the higher the energy. We can think of this as taking a given wave and squeezing it into a smaller or bigger box: the wave in the smaller box has a higher frequency and hence a higher energy. The electrons are behaving like waves as they move around the box. The color of the dye is the combination of wavelengths in white light not absorbed by the dye, so the color seen is the conjugate of the color of light absorbed by the dye. Students can relate the size of a dye molecule to its color and the color it is absorbing. (Molecular structure can be obtained from the chemical supplier.)

The standard reference for this experiment is Shoemaker, D. P., C. W. Garland, and J. W. Nibler, *Experiments in Physical Chemistry*. New York: McGraw-Hill (1996).

Another version on the web, from the University of Nebraska-Lincoln:

<http://www.chem.unl.edu/chem484/conjdye/>

MATH

GRAPHING

In preparing the graph of energy vs. frequency, students should be able to recognize the $y = mx + b$ form, where $b = 0$ in the model we are using. Some good questions to raise include:

- Finding a best fit line (by eye using graph paper, with a graphing calculator, or on a computer) to relate frequency to energy.
- Discussing what units the slope of the equation has.
- Thinking about why the intercept of the line might or might not be at the origin.
- Talking about experimental error, scatter of points, and the comparison of a group's data point to the plot for the entire class.
- Where extrapolations/interpolations are valid.

TRIGONOMETRY

The waves of light take on sinusoidal forms, providing many connections to frequency, period, wavelength, and even phase.

Applet showing electric and magnetic components of light as sinusoids
<http://www.phy.ntnu.edu.tw/~hwang/emWave/emWave.html>

PHYSICS

Many connections are possible: voltage rules in circuits, electromagnetic spectrum, blackbody radiation, energy levels, spectral lines, color mixing, diffraction, wave-particle duality, photoelectric effect, semiconductors, etc. In fact, much of twentieth-century physics has been involved with the concepts raised here!

For a college-sophomore level physics textbooks which covers most of the physics topics mentioned above, refer to: R. A. Serway, C. J. Moses, C. A. Moyer. *Modern Physics*. Saunders College Publishing (1998).

Red, green, and blue color-mixing applet
<http://www.phy.ntnu.edu.tw/~hwang/image/rgbColor.html>

Applet showing electric and magnetic components of light
<http://www.phy.ntnu.edu.tw/~hwang/emWave/emWave.html>

University of Colorado, Boulder: "Physics 2000"
<http://www.colorado.edu/physics/2000/index.pl>

One possible extension of the lab exercise for older students would be to have them research and present some of the biology, chemistry, and astronomy connections based on their knowledge of physics.

TECHNOLOGY

Students can brainstorm ways in which LED technology is found in everyday devices: computer indicator lights, on/off on stereos, some new flashlights, etc. Efficiency of devices can be discussed via the difference between LEDs and incandescent lightbulbs. If the students assemble the circuits themselves, soldering skills and the interpretation of schematic diagrams are involved.

David Macaulay's *The Way Things Work* or *The New Way Things Work* Contains information on many devices which make use of these concepts, in a fun and pictorial format.

LED Museum
<http://ledmuseum.home.att.net/>